

Product Datasheet - Technical Specifications



More information in our Web-Shop at ► www.meilhaus.com

Your contact

Technical and commercial sales, price information,
quotations, demo/test equipment, consulting:

Tel.: **+49 - (0)81 41 - 52 71-0**

FAX: **+49 - (0)81 41 - 52 71-129**

E-Mail: sales@meilhaus.com

Meilhaus Electronic GmbH
Am Sonnenlicht 2
82239 Alling/Germany

Tel. **+49 - (0)81 41 - 52 71-0**
Fax **+49 - (0)81 41 - 52 71-129**
E-Mail sales@meilhaus.com

Mentioned company and product names may be registered trademarks of the respective companies. Errors and omissions excepted. © Meilhaus Electronic.

5 μ H Line Impedance Stabilisation Network

1 Introduction

The TBOH01 5 μ H LISN is a device required to setup conducted noise measurements of DC-powered devices. It is designed to be used for EMC pre-compliance testing in the frequency range of 150kHz to 110 MHz according to the CISPR-25 standard, ISO 7637-2, ISO11452-2/4/5 and with limitations DO-160/ED-14G.

The LISN is inserted into the supply line of the DUT (Device Under Test). Conducted noise which is present at the supply terminals of the DUT is measured at the BNC connector using a spectrum analyzer or a measurement receiver. The source (supply) terminal and the DUT terminal are decoupled with a 5 μ H inductor.

This manual is applicable for TBOH01 SNR \geq 16146. For TBOH01 with a lower serial number, refer to chapter 3.



1.1 Parameters

Frequency range: 100 kHz – 110 MHz (1GHz, see figure 4)

DC Resistance: 40 m Ω

Maximum current: 10A

Nominal operating voltage range: 0 – 60V DC;

Absolute maximum rating: 200V

Built in surge protection

Terminals suitable to clamp external source capacitors

5μH Line Impedance Stabilisation Network

1.2 Schematic

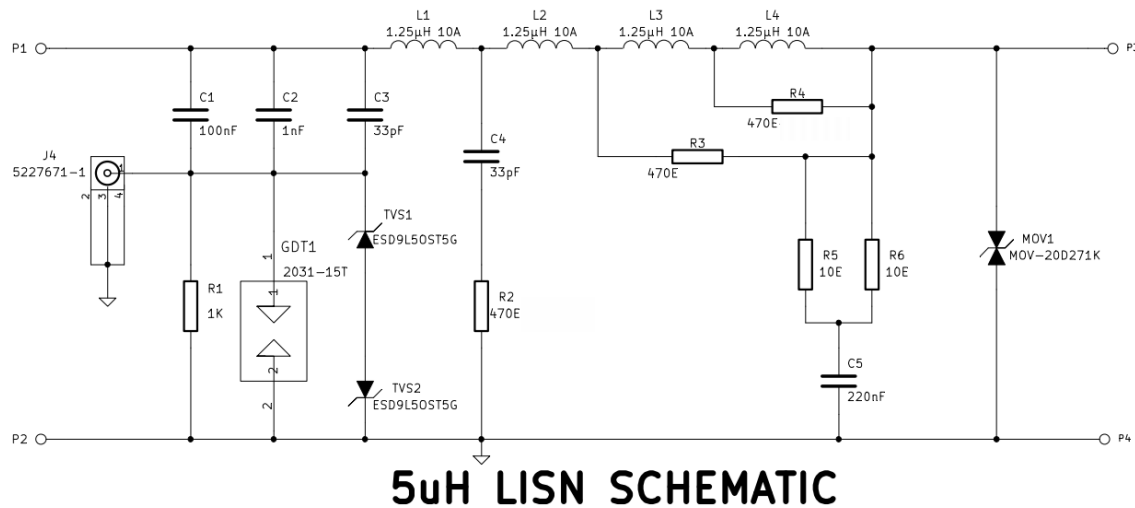

Figure 1: TBOH01 5μH LISN schematic

P1: DUT+; P3: Source+; CON1: Spectrum Analyzer / Measurement Receiver

BOM:

C1	C3216X7R2E104K	100nF 250V X7R 1206	TDK Corporation	Digikey
C2	1206PC102KAT1A	1nF 250V X7R 1206	AVX	Digikey
C3	501R18N330JV4E	33pF 500V NP0 1206	Johanson	Digikey
C5	C3225X7R2E224M	220nF 250V X7R 1210	TDK Corporation	Digikey
CON1	DOSIN-801-0034	BNC 50Ω 180° PCB mount	Dosin	Dosin
		Ms. Blanche Li	dosin2012@dosin-china.com	
GDT1	2031-15T-SM-RPLF	GAS TUBE 60V 1KA	Bourns Inc.	Digikey
HOUSING	1550DBK or 1550D	BOX ALUM 4.51X2.52X2.17"	Hammond	Digikey
L1, L2, L3, L4	1.25μH; 8 turns, Ø 17mm	Ø1,4mm enameled copper wire		
MOV1	MOV-20D271K	VARISTOR 270V 20MM	Bourns Inc.	Digikey
P1, P2, P3, P4	Banana Jacks			
PCB	5μH LISN V1.0	double sided, 95x58x1.6mm	FZ-Electronics	FZ
		Ms. Lisa Yang	lisayang@fzelectronics.com	
R1	RC1206FR-071KL	RES 1K OHM 1/4W 1% 1206	Yageo	Digikey
R3, R4	4-1622820-8	RES 470 OHM 1W 5% 2512	TE Connectivity	Digikey
R5, R6	1622820-4	RES 10 OHM 1W 5% 2512	TE Connectivity	Digikey
TVS1, TVS2	ESD9L5.0ST5G	TVS ULT LOW CAP SOD-923	ON-Semiconductor	Digikey
C4, R2	do not populate			

5 μ H Line Impedance Stabilisation Network

1.3 Impedance

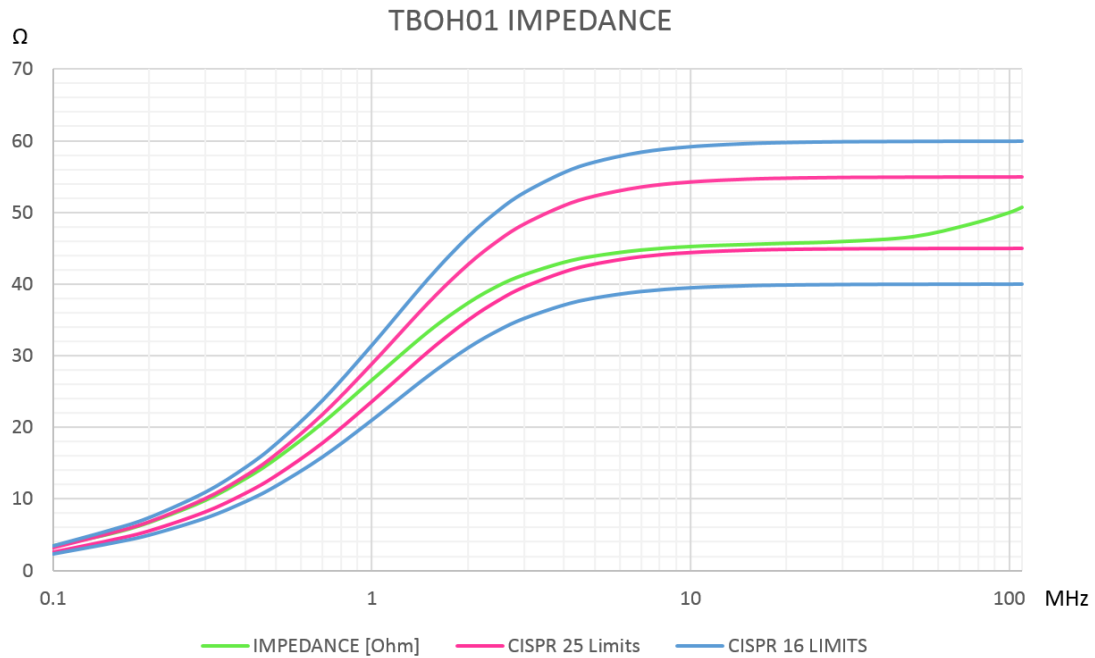

Figure 2: 100 kHz – 110 MHz, measured impedance of the TBOH01 5 μ H LISN, source terminals shorted

1.4 Isolation

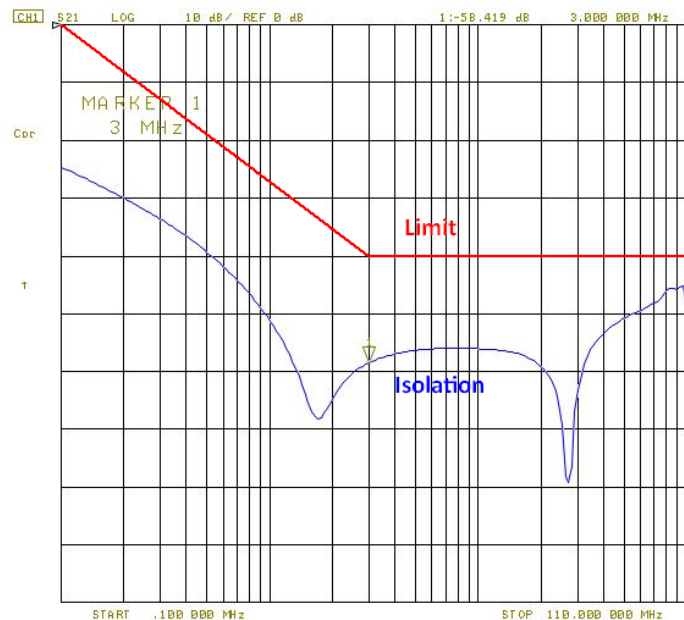

Figure 3: 100 kHz - 110MHz, isolation measured between DUT and source terminals; BNC connector terminated with 50 Ω

5 μ H Line Impedance Stabilisation Network

1.5 Voltage Division Ratio

Calibration set up according to CISPR 16-1-2 Annex A.8.

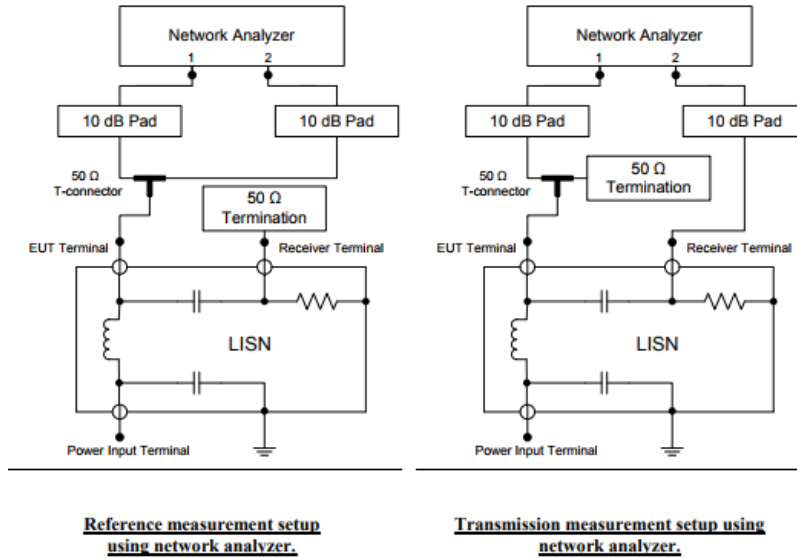

Figure 4 – Calibration set up according to CISPR 16-1-2 Annex A.8.

The voltage division ratio is a correction factor that needs to be applied to the levels measured at the LISN RF output.

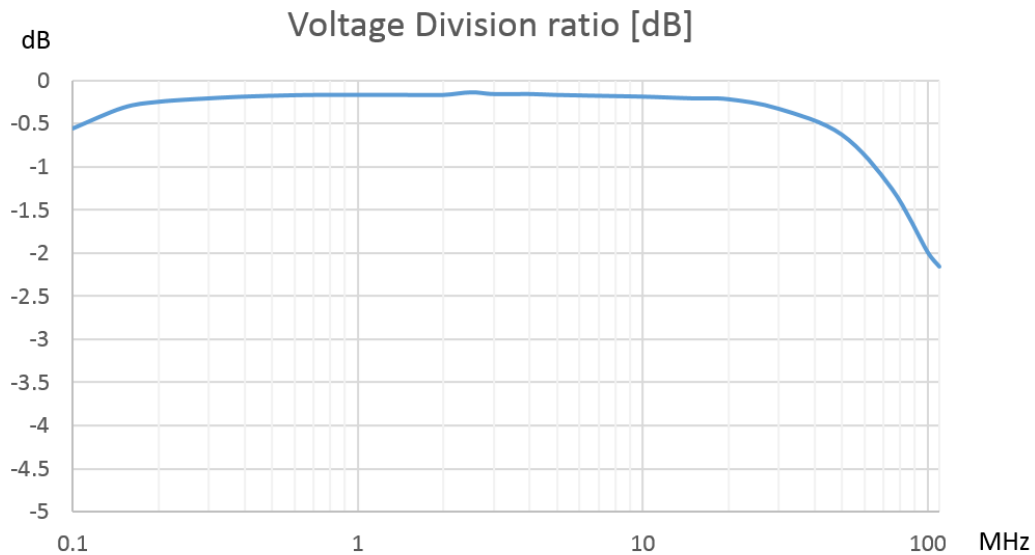

Figure 5: 100 kHz - 110MHz, voltage division ratio according to CISPR 16-1-2 Annex A8; source terminal 1 μ F

5 μ H Line Impedance Stabilisation Network

Frequency [MHz]	Voltage division ratio [dB]; source terminals: 1 μ F
0.1	-0.56
0.15	-0.32
0.2	-0.25
0.3	-0.21
0.4	-0.19
0.5	-0.18
0.7	-0.17
1	-0.17
1.5	-0.17
2	-0.17
2.5	-0.14
3	-0.16
4	-0.16
5	-0.17
7	-0.18
10	-0.19
15	-0.21
20	-0.22
30	-0.33
50	-0.63
75	-1.26
100	-1.99
110	-2.16

Table 1: 100 kHz – 110 MHz, voltage division ratio according to CISPR 16-1-2 Annex A8; source terminal 1 μ F

A correction file with the voltage division ratio for use with the EMCview software can be downloaded from the TBOH01 product page.

1.6 Phase

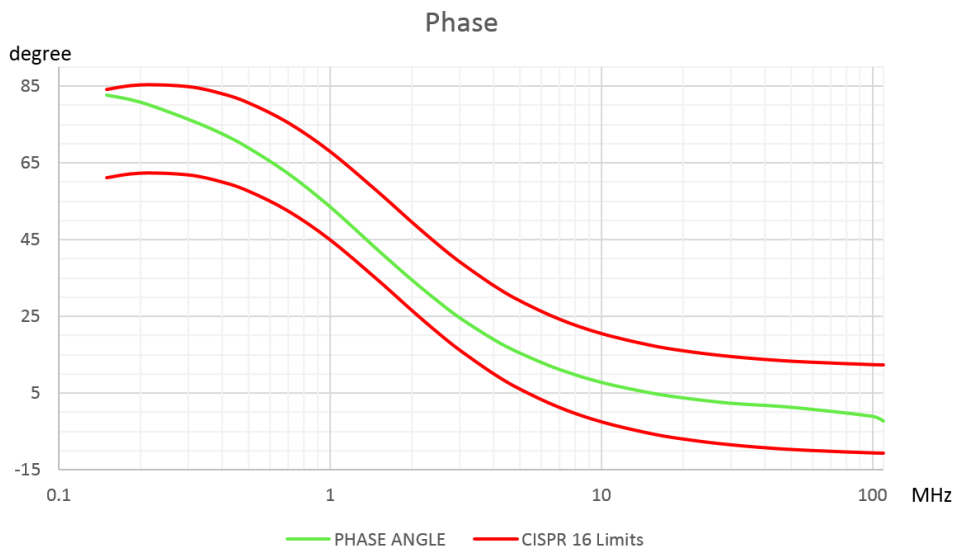

Figure 6: 150 kHz – 110 MHz, Phase angle of impedance; RF output terminated with 50 Ω , source terminal shorted

5µH Line Impedance Stabilisation Network

1.7 Frequency response

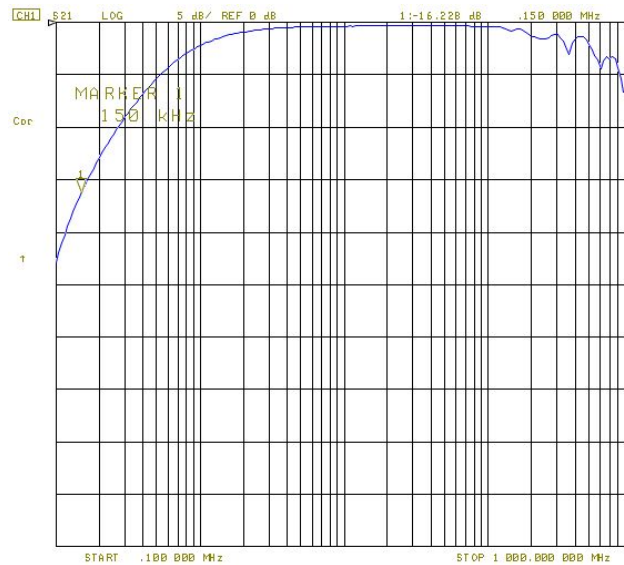

Figure 7 – 100 kHz...1 GHz, insertion loss measured between DUT terminals and BNC connector; source terminals 1µF

Frequency	insertion loss DUT terminals to BNC; source terminals 1µF
150 kHz	-16.3 dB
200 kHz	-12.8 dB
250 kHz	-10.7 dB
300 kHz	-9.1 dB
350 kHz	-7.8 dB
400 kHz	-6.7 dB
450 kHz	-5.9 dB
500 kHz	-5.1 dB
600 kHz	-4.2 dB
700 kHz	-3.5 dB
800 kHz	-3 dB
900 kHz	-2.5 dB
1 MHz	-2.2 dB
5 MHz	-0.5 dB
10 MHz	-0.4 dB
50 MHz	-0.3 dB
100 MHz	-0.5 dB
150 MHz	-0.8 dB
200 MHz	-1.3 dB
250 MHz	-1.6 dB
300 MHz	-1.2 dB

Table 2, insertion loss measured between DUT and BNC terminal; Source terminals open/shorted

Note that the frequency response plot has only informative character. The relevant correction factor for conducted noise measurements is the voltage division ratio.

1.8 Source capacitors:

For CISPR 25 and ISO 11452-2/4/5 conducted noise tests, add a 1µF capacitor in parallel to the source terminals. The TBOH01 terminals have perpendicular holes to easily insert and clamp the pins of the external capacitor. DO-160 specifies a 10µF capacitor in parallel to the source terminals. However, consider that the TBOH01 is not specified for the full DO-160 frequency range. ISO7637-2 does not specify an external capacitor.

5 μ H Line Impedance Stabilisation Network

2 Application

The abbreviation LISN stands for Line Impedance Stabilisation Network.

- It is a low pass filter typically placed between a power source and the supply terminals of a device under test (DUT).
- It has a feed-through path to supply the DUT with power
- It provides a well-defined RF-impedance to the DUT
- It couples electrical noise generated by the DUT to a 50 Ω RF port, which can be connected to a spectrum analyser or measurement receiver
- It suppresses electrical noise from the supply side towards the DUT
- It suppresses electrical noise from DUT side towards the supply

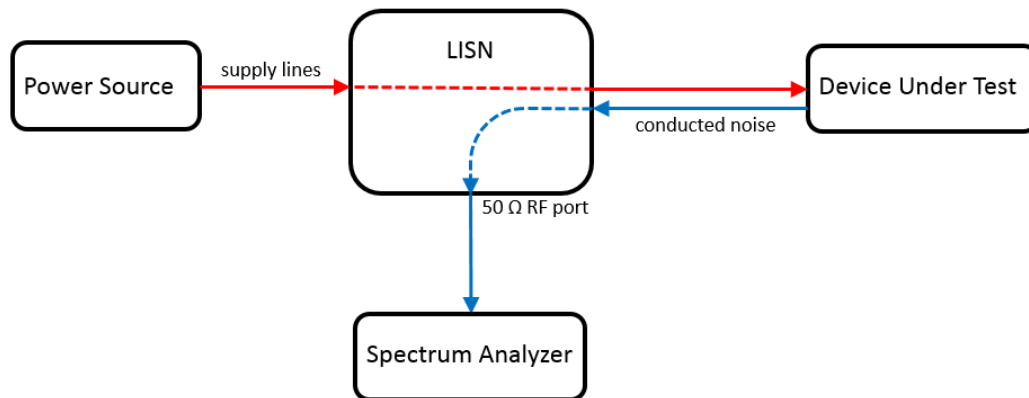

Figure 8: Basic diagram of a conducted emission measurement setup with a LISN

Further applications such as conducted noise measurements using RF current monitoring probes, BCI tests and voltage transient tests require LISNs to establish a defined supply line impedance.

2.1 Conducted Emission Measurement Setup, Voltage Method

CISPR 25 specifies two measurement configurations:

If the DUT is grounded to the vehicle chassis with a power return line shorter than 20 cm, a single 5 μ H LISN is sufficient and the conducted noise will only be measured on the positive supply line.

If the power return line of the DUT is longer than 20 cm, two 5 μ H LISNs are required. The positive supply line is connected to the DUT via one LISN and the power return line is connected to the DUT via another LISN.

Conducted noise is measured on both lines. In fact, it is measured on one LISN at a time, while the RF port of the other LISN is terminated with a 50 Ω resistor.

Professional conducted noise measurements are done in shielded chambers, as any RF smog picked up by the wires from LISN to DUT or by the DUT itself, will be present at the RF terminal. Consequently, a measurement with the DUT powered off should be done upfront in order to distinguish between real conducted noise generated by the DUT and RF smog from other sources (ambient noise).

Tekbox offers low cost, desktop shielded tents or shielded bags to suppress ambient noise when carrying out pre-compliance conducted noise measurements.

5 μ H Line Impedance Stabilisation Network

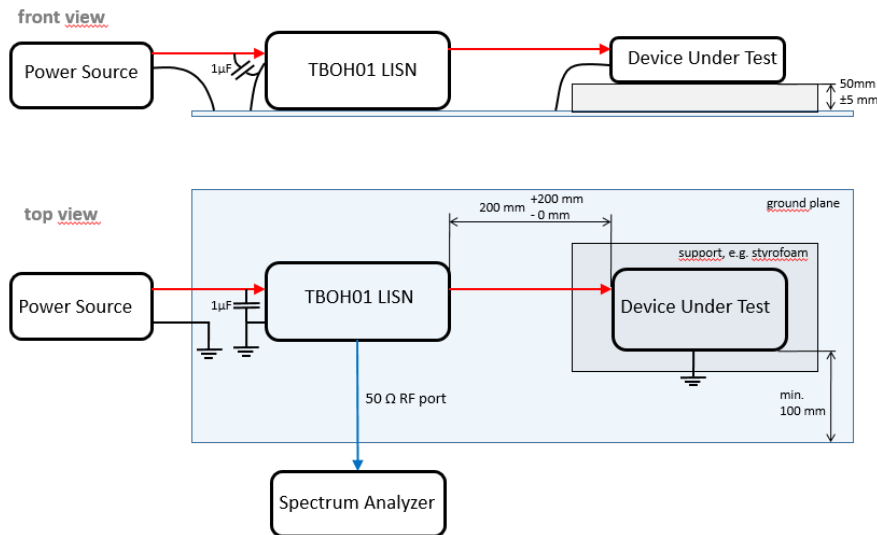

Figure 9: conducted emission measurement, voltage method, DUT with power return line locally grounded

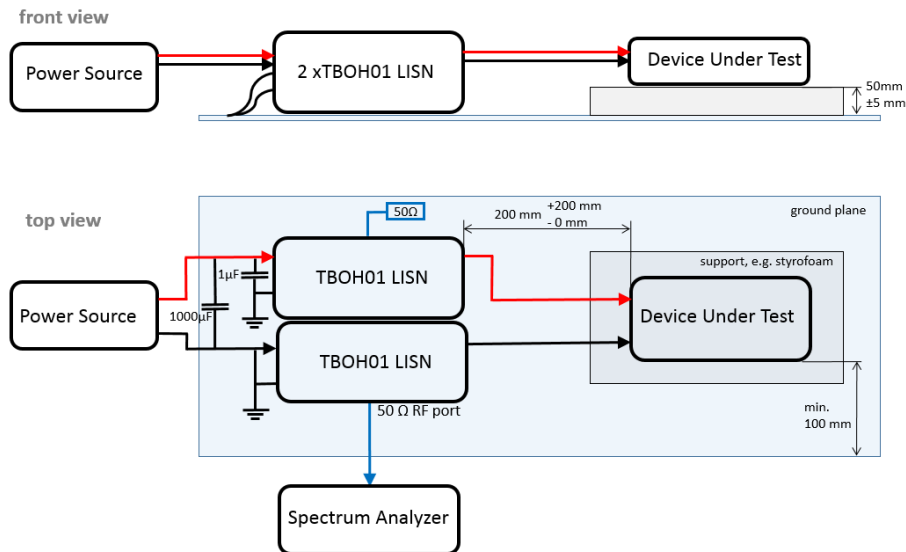

Figure 10: conducted emission measurement, voltage method, DUT with power return line remotely grounded

Figure 9 and figure 10 show conducted noise measurement set ups, voltage method, according to CISPR 25. In case that the DUT is connected to other peripheral devices, they should be connected as well, or simulated with a load box. If the housing of a remotely powered DUT foresees chassis grounding, it should be grounded to the ground plane as well. The grounding lead should not be longer than 150mm then.

A set up according picture 4 is more common, as most devices are remotely grounded.

The measurement needs to be alternatively carried out on both the positive and negative power line then. The unused RF port is always terminated with 50 Ohm.

Note that conducted noise testing according to DO160 requires an additional 10 μ F capacitor across the source terminals of the LISN.

5µH Line Impedance Stabilisation Network

2.2 Conducted emission measurement set up, current probe method

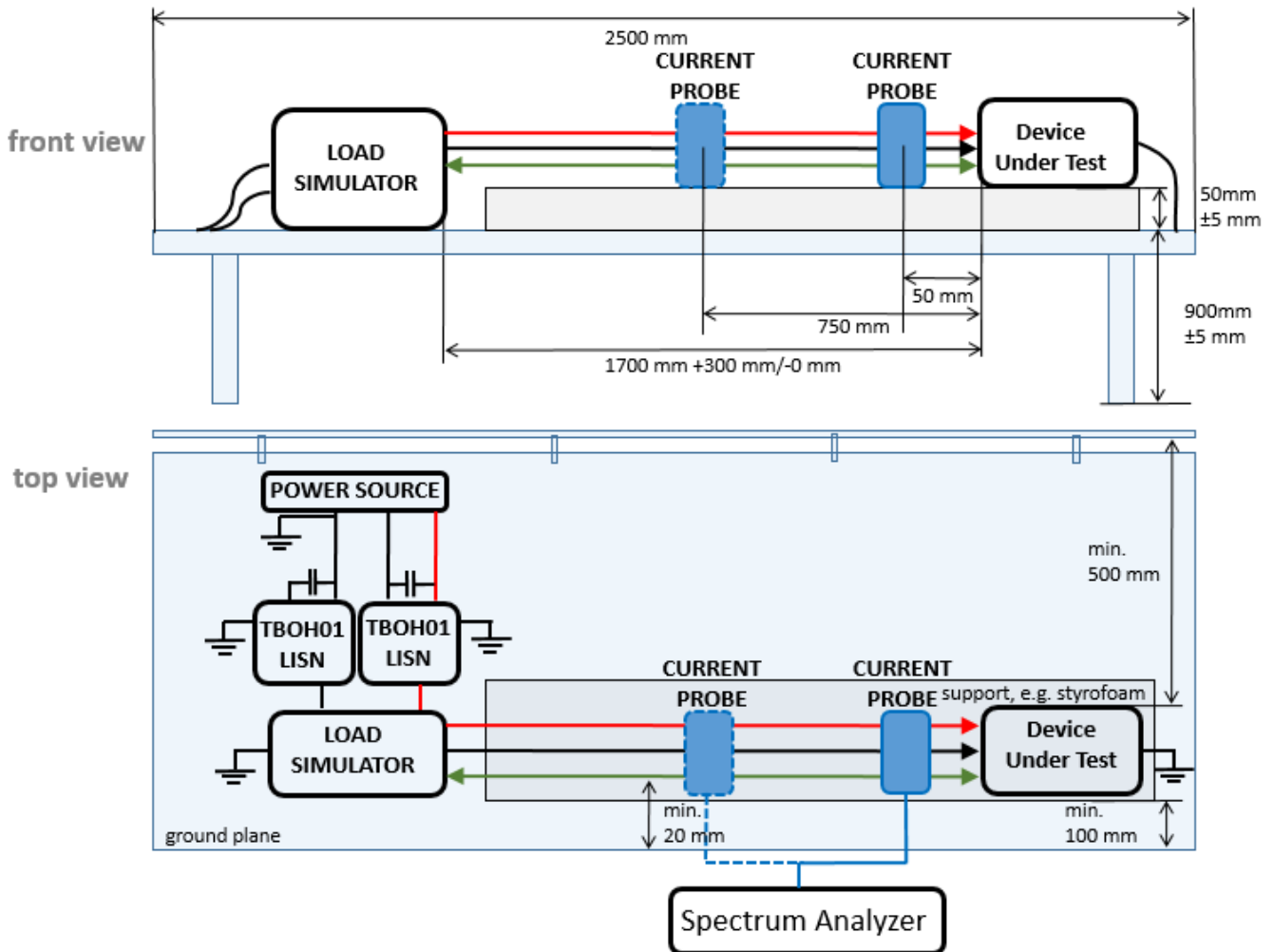

Figure 11: conducted emission measurement according to CISPR 25, current probe method

The current probe measurement according to CISPR 25 is used to measure conducted emissions on a wire harness including control/signal lines of a DUT. However, it is also used by some automotive manufacturers to measure power supply lines instead of applying the voltage method. Measurements are typically taken on various lines – plus, minus, control signals, plus + minus, plus + minus + control lines. The current probe measurement is carried out in 50 mm distance and in 750 mm distance from the EUT in order to cover resonance effects of the cable harness. The RF output of each LISN must be terminated with 50 Ohm. A current probe picks up the conducted emissions. Two LISNs are required to establish a defined impedance on the power lines. The load simulator is a customized device that simulates the load present at the signal/control interface of the DUT.

For more details refer to our application note AN Conducted Noise Measurement _Tekbox LISN TBOH01 and EMCview_V1_2.

5 μ H Line Impedance Stabilisation Network

2.3 Bulk Current Injection

Immunity tests according to ISO11452-4 use a similar setup as for current probe based conducted emission measurements. However, instead of using a current probe to measure conducted emissions, a signal generator / power amplifier feeds an interferer signal into the current probe. Again, two 5 μ H LISNs are required to establish a defined supply impedance. The RF output of the LISN needs to be terminated with an external 50 Ohm termination of suitable power handling capability.

2.4 Voltage transient testing

When using the LISN for voltage transient testing according to ISO 7637-2, the 1 μ F capacitor at the source input of the LISN needs to be disconnected in order to avoid shorting the transient. Furthermore, depending on the voltage level of the applied pulses, it may be necessary to remove the protective (voltage limiting) components such as the TVS diodes, gas discharge tube and MOV. Also note that the TBOH01 impedance is outside the very tight limits specified by ISO 7637-2.

2.5 Setup for measuring power supply noise spectrum of power supplies

During product development, LISNs are useful to investigate the noise spectrum at the output terminals of power supplies or switched mode regulators.

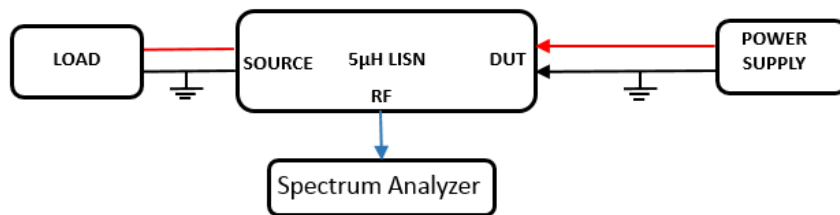

Figure 12: setup for measuring power supply noise spectrum

2.6 Setup for RF immunity testing

By adding a 50 Ohm feed through termination, the LISN can also be used to inject RF into the supply line of the DUT. The power rating of the feed through termination has to match the injected RF power level. Note that this is not a standard conformant method. These inject RF via CDN or BCI probes.

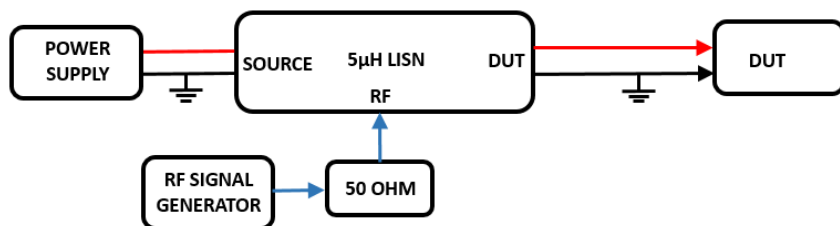

Figure 13: setup for RF injection

5 μ H Line Impedance Stabilisation Network

3 Hardware change notice

This manual is applicable for TBOH01 LISN with serial number 16146 and higher. If you received this manual together with the LISN, it is already applicable. The TBOH01 is an open hardware design to provide a simple, low cost LISN for EMC pre-compliance testing. Starting with SNR 16146, the TBOH01 was modified to match impedance characteristics with shorted source terminals for frequencies below 1 MHz and characterized over a wider frequency range than previously.

If your LISN serial number is lower than 16146, you can easily update the hardware with a simple modification. Open the 4 screws on the bottom of the LISN and unsolder C4. Refer to the component number on the silk screen of the PCB or the schematic in chapter 1.2 of this manual. Next take needle nose pliers and break away the tiny ferrite beads attached to L3 and L4. Close the housing and done.

The effect of the HW modification on voltage division ratio is only marginal. An updated correction file for EMCview can be downloaded from the TBOH01 product page.

4 Ordering Information

Part Number	Description
TBOH01	5 μ H LISN

Table 3 – Ordering information

5 History

Version	Date	Author	Changes
V1.0	14.09.2010	L.D.HIEU	Creation of the document
V1.1	18.11.2013	L.D.HIEU	Chapter 2 updated
V1.2	17.03.2014	L.D.HIEU	Part number of R2 corrected
V1.3	25.11.2014	MAYERHOFER	Chapter 1.1 updated
V1.4	17.01.2016	MAYERHOFER	Insertion loss table added
V1.5	8.8.2016	MAYERHOFER	Picture 12 added
V1.6	24.4.2017	MAYERHOFER	Updated chapters 1, 1.4, 3, 4
V1.7	13.12.2017	MAYERHOFER	Chapter 1.5 added
V1.8	20.4.2021	MAYERHOFER	Complete rework of the manual, following a HW update of the TBOH01

Table 4 – History